

ACOUSTIC DOOR

AS-39-PYROL-E

TECH SHEET—AS-39-PYROL-E

Issue: 13-12-04

2 hr fire rated 39 Rw single acoustic / smoke door

DESCRIPTION

Pyropanel AS-39-PYROL is a 39 Rw, 2 hour fire rated 55mm single leaf acoustic door that utilises a Pyropanel Euroseal® concealed perimeter smoke / acoustic seal and a Raven RP8 bottom seal. This door comes standard with steel faces.

APPLICATIONS

Ideal for applications that require up to 2 hours of fire resistance and an acoustic rating of 39 Rw, such as warehouse, factories and fire escapes.

FEATURES

Acoustic Rating

- 39 Rw (39 STC)

Test Certificate number

- TL373(r)

Fire Resistance

- -/120/30

Door Configuration

- Single leaf hung in a steel frame

Perimeter Seal

- Pyropanel Euroseal® concealed smoke / acoustic seal

Bottom Seal

- Raven RP8

Thickness

- 55mm (Nominal)

Size

- Maximum Size - 2400 x 1020 (-/60/30)
- 2100 x 920 (-/120/30)

Hinges

- Minimum 3 steel hinges

Frame

- Packed pressed metal frame (2 hr)
- Timber or packed pressed metal frame (1 hr)

Finish

- 2hr FRL - Metal facing one side, Ply facing on the other
- 1hr FRL - Metal facing one side, Ply or MDF on the other

OPTIONAL EXTRAS

- Pre-hung in timber or steel frame where appropriate (check FRL)
- Steel, Veneer or Laminate facings can be applied over existing face
- Stainless steel faces
- Vision panels - 300 x 200 or 250 x 250mm.
- Kick Panels of 1.2mm Stainless Steel to selected height
- Meets the BCA requirement for a smoke door.

INSTALLATION

Door frame must be tightly sealed against wall structure using Pyropanel Multiflex or approved alternative fire and acoustic sealant. Metal door frames will require packing with Pyropanel FR board, Fire rated plaster, concrete or mortar to achieve desired acoustic and fire rating.

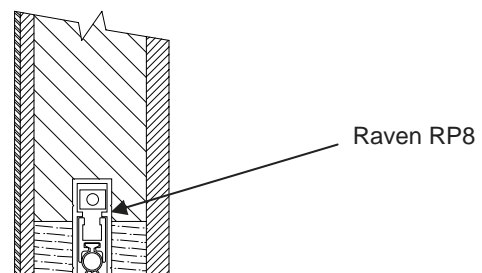
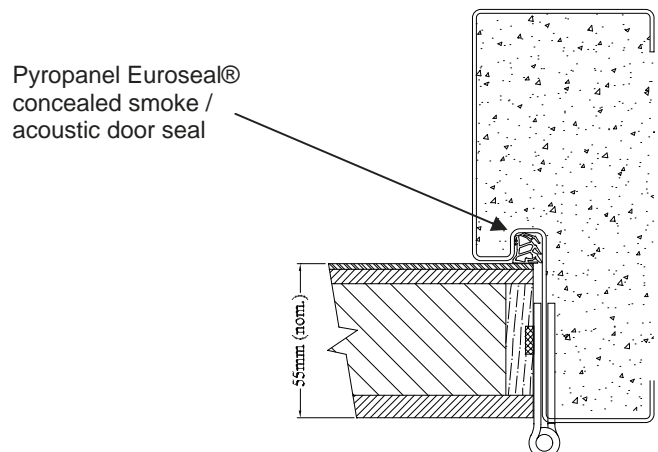

HOW TO SPECIFY

"Door to be a Pyropanel AS-39-PYROL-E acoustic door with -/120/30 FRL and installed into a timber (1hr)* or packed pressed metal door frame (2hr)*"*

* denotes example—delete, change or specify as required



Pyropanel Developments Pty Ltd
122-124 Beresford Rd, Lilydale, VIC, 3140
Ph: (03) 9735 5688 Fax: (03) 9739 5772
Email: sales@pyropanel.com.au
Web: www.pyropanel.com.au

Distributed by: