

ACOUSTIC DOOR

AS-31-PAN

TECH SHEET: AS-31-PAN

Issue: 22-03-07

60 minute fire rated 31 Rw single acoustic / smoke / fire door

DESCRIPTION

Pyropanel AS-31-PAN is a 31 Rw 1 hour fire rated 48mm single leaf acoustic door that utilises a Raven Products RP10 perimeter seal and an RP99 bottom seal.

APPLICATIONS

Ideal for unit entry applications or anywhere that requires 60 minutes of fire resistance and an acoustic rating of 31 Rw.

FEATURES

Acoustic Rating

- 31 Rw (31 STC)

Test Certificate number

- TL373(m)

Fire Resistance

- FRL -/60/30

Door Configuration

- Single leaf hung in a steel or timber frame.

Perimeter Seal

- Raven RP10

Bottom Seal

- Raven RP99

Thickness

- 48mm (Nominal)

Size

- Maximum Size - 2420 x 1020

Hinges

- Minimum 3 steel hinges

Frame

- Pyropanel KDHW timber or packed pressed metal frame

Finish

- MDF as standard

OPTIONAL EXTRAS

- Pre-hung in steel or timber frame
- Ply, Veneer, Steel or Laminate facings
- Vision panels - 300 x 200 or 250 x 250mm.
- Kick Panels of 1.2mm Stainless Steel to selected height
- Meets the BCA requirement for a smoke door.

INSTALLATION

Door frame must be tightly sealed against wall structure using Pyropanel Multiflex or approved alternative fire and acoustic sealant. Metal door frames will require packing with Pyropanel FR board, Fire rated plaster, concrete or mortar to achieve desired acoustic rating.

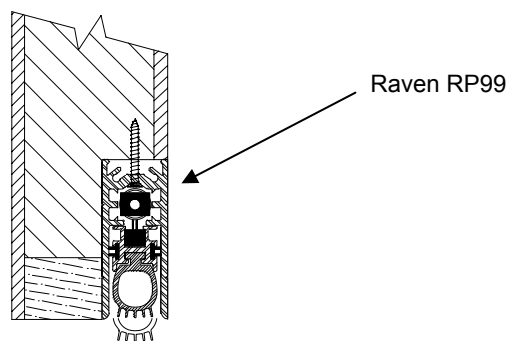
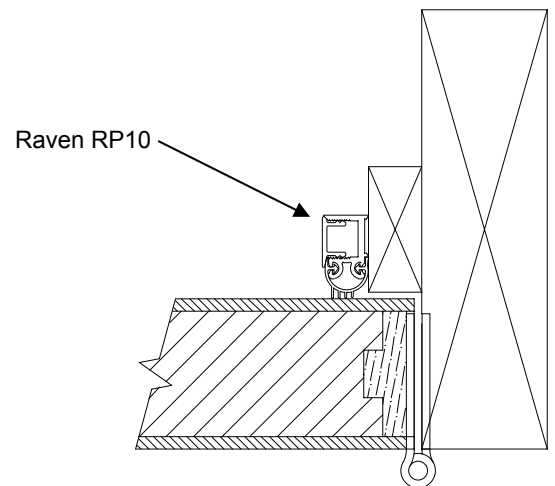

HOW TO SPECIFY

"Door to be a Pyropanel AS-31-PAN acoustic door with -/60/30 FRL, installed into a Pyropanel Fire rated timber / packed metal* door frame"*

* denotes example—delete, change or specify as required

PYRO PANEL

Protecting Life and Property

Pyropanel Developments Pty Ltd
122-124 Beresford Rd, Lilydale, VIC, 3140
Ph: (03) 9735 5688 Fax: (03) 9739 5772
Email: sales@pyropanel.com.au
Web: www.pyropanel.com.au

Distributed by: